



ZP-1

BLIMP-STYLE MICROPHONE
WINDSCREEN &
SHOCKMOUNT

ZP-1

Blimp-Style Microphone Windscreen & Shockmount

The Marantz Professional ZP-1 is designed for film and television production audio, and any sound-gathering situation where reliable protection from wind noise is needed. The ZP-1 guarantees versatile assimilation into a diverse range of field recording scenarios courtesy of a fully-adjustable internal microphone suspension and shock-mount system, accommodating shotgun microphones up-to 14.5" long – premium protection from residual noise generated by minor knocks and boom handling. For rapid adjustments on the fly, the ZP-1 conveniently includes twist-on end caps and a rail-based mounting system – simply loosen the front and rear clamping levels for changing / inserting microphones or adjusting the location of the shock mount bands for optimum microphone balance. For added convenience, the ZP-1 includes a molded pistol grip with integral microphone cable for ease of use when swapping out mics and facilitating rapid setup / pack-down time. For critical protection against wind-noise, a synthetic fur slip-on cover is included that increases wind noise attenuation up to 50dB – ideal for field-recordings, outdoor location shoots, interviews and more. With a threaded 3/8" stud and weighing in at 60kg, the ZP-1 seamlessly mounts to industry standard booms whilst providing a lightweight, versatile and durable mic operation solution - an essential tool for any field production kit.

Features

- Blimp-style microphone windscreen for boom pole or handheld use
- Adjustable internal microphone suspension system

- Accommodates microphones up to 14.5" long
- Pistol grip with integral microphone cable and threaded for 3/8" stud
- Includes grey synthetic fur slip-on cover for additional wind noise attenuation
- Twist-on endcaps

Box Contents

- ZP-1
- Shockmount bands
- Synthetic fur windscreen
- User guide
- Safety and warranty manual

Windscreen Diagrams

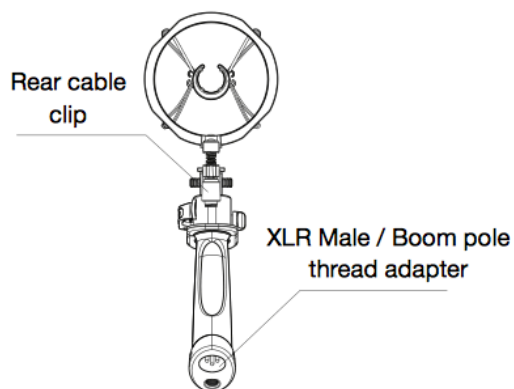
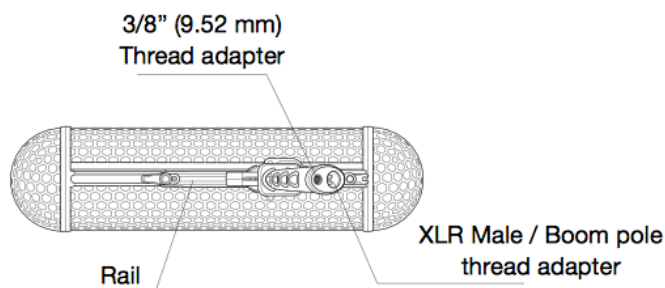
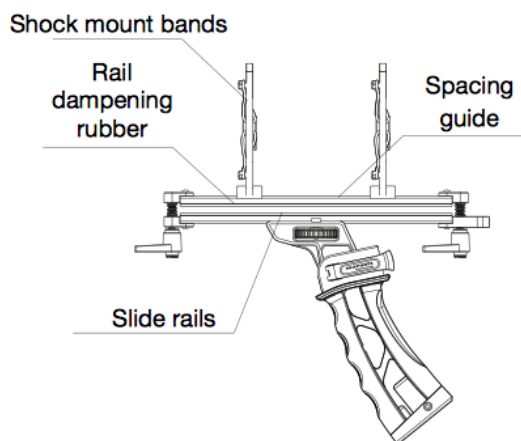
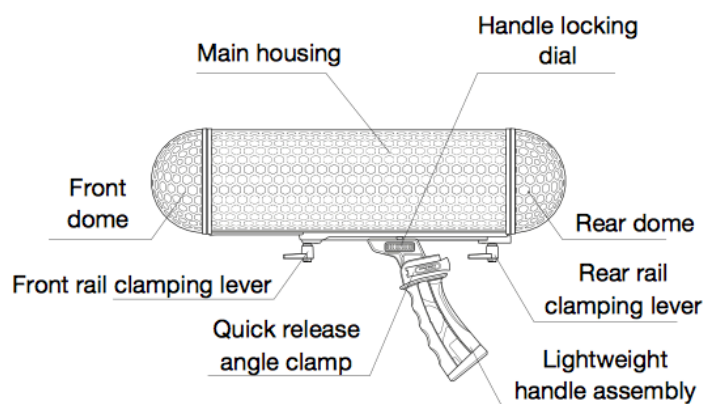

Technical Specifications

Supported Microphone Size	Shotgun microphones: Length: 14.5" / 368 mm Diameter: 0.78"-0.88" / 20-22.5 mm
Dimensions (length x height)	18.5" x 4.75" / 470 x 121 mm
Weight	1.32 lbs. / 0.60 kg (ZP-1) 1.63 lbs. / 0.74 kg (ZP-1 with synthetic fur windscreen)

User Summary & Target Demographics

The primary target market for the Marantz Professional ZP-1 film based sound operators, field-based recording engineers and outdoor Foley artists seeking a protective solution for shotgun microphones when recording in windy conditions. With the ZP-1, simple assembly combines with a premium build, noise attenuation up to 50dB and accommodation of microphones up to 14.5" in length, providing this specialist target market with a light-weight, versatile and durable solution for field based recording scenarios.