

# V-BR 002

## PAIR OF VERTICAL BRACKETS

### DESCRIPTION

Pair of brackets for 12" cabinets vertical wall mounting.



### FEATURES

- Strong steel construction
- Adjustable inclination
- Painted with scratch resistant paint
- Flying mounting allowed

**TECHNICAL SPECIFICATIONS**

|                                |                        |                       |
|--------------------------------|------------------------|-----------------------|
| <b>Standard compliance</b>     | Safety agency:         | CE compliant          |
| <b>Physical specifications</b> | Cabinet/Case Material: | Steel                 |
|                                | Color:                 | Black - RAL 9005      |
| <b>Size</b>                    | Height:                | 435 mm / 17.13 inches |
|                                | Width:                 | 374 mm / 14.72 inches |
|                                | Depth:                 | 68 mm / 2.68 inches   |
|                                | Weight:                | 3.3 kg / 7.28 lbs     |
| <b>Shipping information</b>    | Package Height:        | 90 mm / 3.54 inches   |
|                                | Package Width:         | 520 mm / 20.47 inches |
|                                | Package Depth:         | 430 mm / 16.93 inches |
|                                | Package Weight:        | 8.1 kg / 17.86 lbs    |

**PART NUMBER**• **13360533**

V-BR 002

Black - RAL 9005

EAN 8024530021320

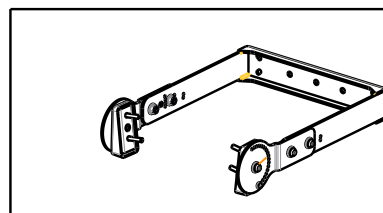
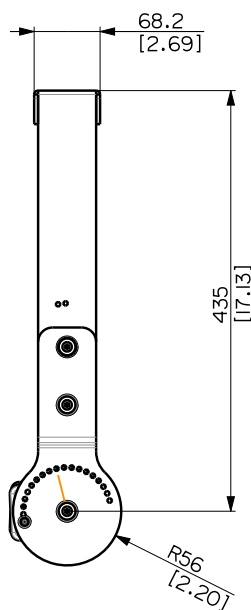
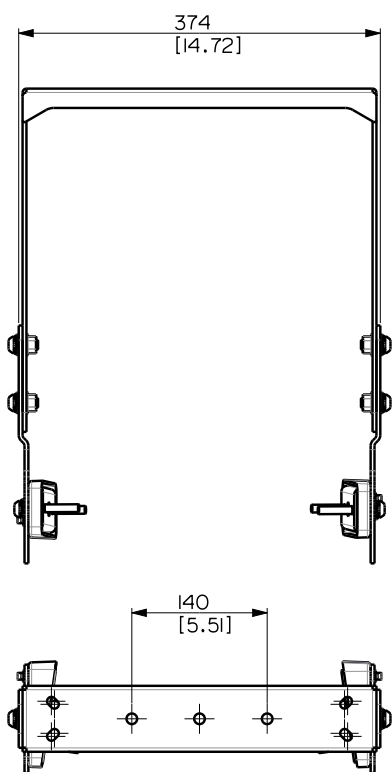

VISTA 3D / 3D VIEW



VERTICAL BRACKET V-BR 002

REV.  
A