

# V-BR TT 08 II

VERTICAL BRACKET



## FEATURES

- SAFE AND QUICK SPEAKER INSTALLATION
- ADJUSTABLE INCLINATION
- PAINTED WITH BLACK, SCRATCH RESISTANT PAINT
- STEEL CONSTRUCTION

**TECHNICAL SPECIFICATIONS**

<b>General specifications</b>	Pieces	1
<b>Standard compliance</b>	CE marking:	Yes
<b>Physical specifications</b>	Cabinet/Case Material:	Metal
	Color:	Black
<b>Size</b>	Height:	48 mm / 1.89 inches
	Width:	289 mm / 11.38 inches
	Depth:	324 mm / 12.76 inches
	Weight:	1.7 kg / 3.75 lbs
<b>Shipping informations</b>	Package Height:	60 mm / 2.36 inches
	Package Width:	340 mm / 13.39 inches
	Package Depth:	300 mm / 11.81 inches
	Package Weight:	2.7 kg / 5.95 lbs

**PART NUMBER**

- **13360400**

V-BR TT 08 II

EAN 8024530016296

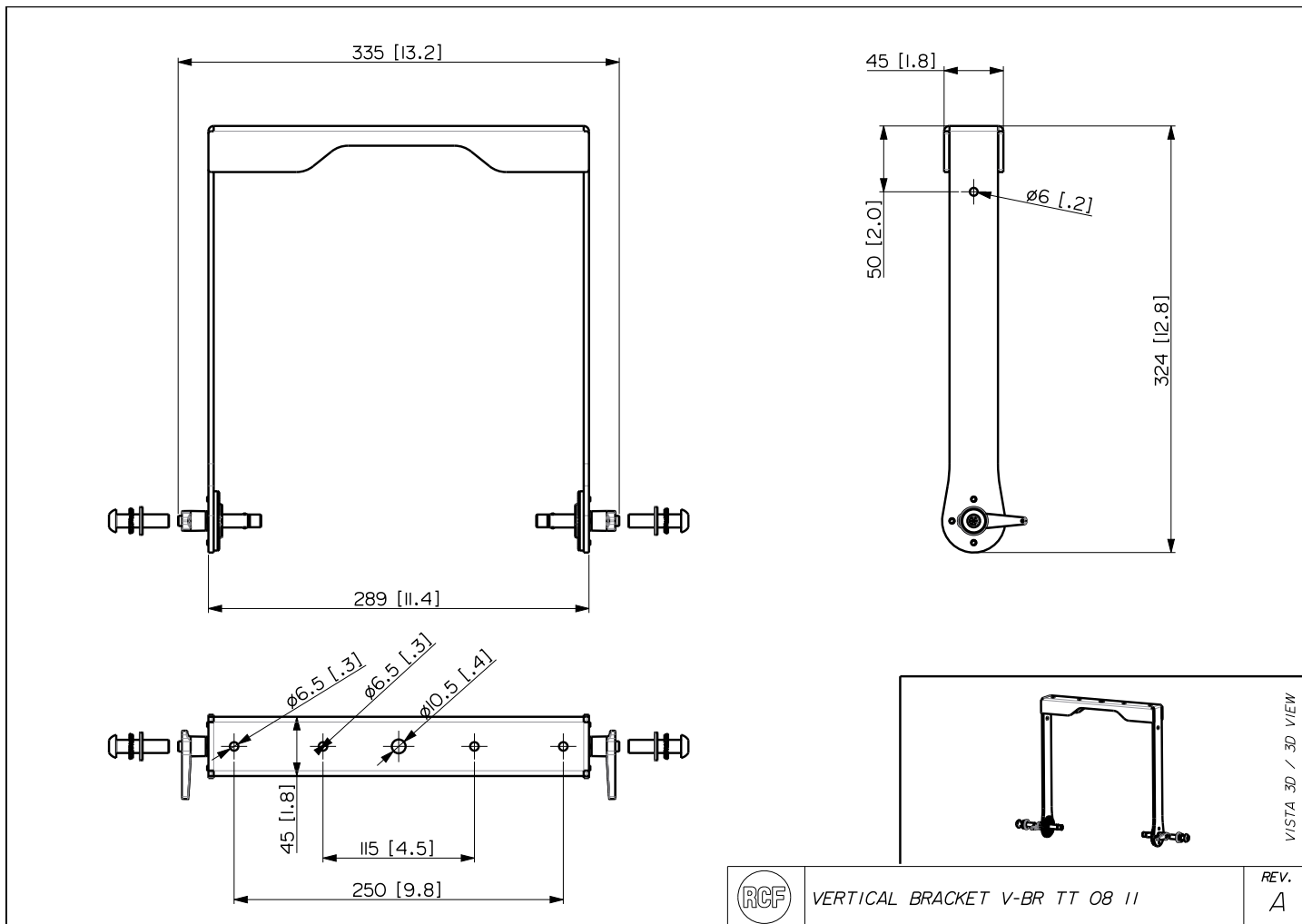

VERTICAL BRACKET V-BR TT 08 II

REV.  
A