



Chord Electronics Ltd.

**ULTIMA PRE - REFERENCE PREAMPLIFIER**  
**USER MANUAL**



# Contents

<b>Product description</b>	<b>Page 3</b>
<b>Inventory</b>	<b>Page 3</b>
<b>Setting up</b>	<b>Page 4</b>
<b>Safety warnings</b>	<b>Page 5</b>
<b>AC Power connection</b>	<b>Page 6</b>
<b>AC Connector</b>	<b>Page 6</b>
<b>Connecting your equipment</b>	<b>Page 7</b>
<b>Input connections</b>	<b>Page 8</b>
<b>Output connections</b>	<b>Page 9</b>
<b>Recording</b>	<b>Page 10</b>
<b>Headphones</b>	<b>Page 12</b>
<b>Everyday use</b>	<b>Page 13</b>
<b>The remote control</b>	<b>Page 16</b>
<b>Maintenance</b>	<b>Page 19</b>
<b>Frequently asked questions</b>	<b>Page 19</b>
<b>Trigger outputs</b>	<b>Page 20</b>
<b>IR Control</b>	<b>Page 20</b>

# Ultima Pre Reference Preamplifier

Thank you for buying a Chord Electronics product.

Before you start to enjoy your preamplifier, please take a couple of minutes to read how to connect your audio equipment and how to maximize your listening experience.

## Product Description

The Ultima Pre is the ultimate high-end reference product and is the perfect partner to the Ultima mono block amplifiers. In the same double height format to match it has all the features of the already advanced CPA5000 but now includes three pairs of outputs, true dual mono construction with separate power supplies for each channel, and separate left and right frequency EQ adjust. Using two separate ultra-high frequency power supplies gives the best possible channel separation and with our latest low noise circuitry the noise floor performance has been improved to beyond -135dB. Each of the power supplies and the sensitive volume, balance and EQ controls is surrounded by solid milled aluminum shielding to prevent RF interference. Extra flexibility is now offered with three pairs of fully balanced XLR or unbalanced RCA phono outputs. Selection can be made manually via the front panel or using the supplied remote control.

Every input has six levels of adjustable gain that can be individually selected to prevent large changes in volume when switching between inputs. All settings are stored via the microprocessor even if power is removed.

## Inventory

As well as your Ultima Pre and this user manual, you should also have received the following items.

1. System Remote Control including user manual
2. Power cord
3. Chord guarantee registration card

# When setting up

To ensure that your Ultima Pre works efficiently and safely, please pay particular attention to the following issues.

## Ventilation

Your Ultima pre should have at least 5cm of clear space all around it to ensure a free flow of air at all times. We do not recommend that you place Ultima Pre directly on a carpet.

## AC lead and plug

All Chord equipment comes supplied with the correct power lead and plug. This should be used at all times.

### If you need to fit a plug for UK/Europe

Connect the blue wire to the neutral terminal  
Connect the brown wire to the live terminal  
Connect the yellow/green wire to the earth terminal

### If you need to fit a plug for US/Canada

Connect the white wire to the neutral terminal  
Connect the black wire to the live terminal  
Connect the green to the earth terminal

## Earthing issues in Europe

In some European countries a hum may occur if your Ultima Pre is connected to mains sockets that do not have an earth. If this is the case please ensure that:

1. Your preamplifier is connected via a multi-way mains block, which contains an earth point at each socket outlet. This is to ensure that the chassis metalwork of each item is connected together.
2. We recommend that an earthing method for your building be implemented.
3. Use the connecting points on your Chord unit and connect to an available earth point.

# Safety Warnings

It is important that your Ultima Pre is earthed at all times via its own mains lead. Failure to do this may be hazardous. The power supply components within the Ultima Pre are designed to operate at lethal voltages and energy levels. Circuit designs that embody these components conform to applicable safety requirements. Precautions must be taken to prevent accidental contact with power-line potentials. Do not connect grounded test equipment.

*There are no user serviceable parts within the Ultima Pre Reference Preamplifier. Unauthorised tampering or dismantling of this product will invalidate the warranty and could cause injury.*

# AC Power connection

The AC power connector of Ultima Pre is at the back of the unit. Plug the female end (socket) of the power cord into the power connector of the preamplifier, and the male end(plug) of the power cord into AC wall socket or AC extension socket. The CPA8000 features universal voltage high frequency power supplies and will operate automatically from 65V to 260V AC, 50 or 60Hz.

*For optimum operation it is recommended that the CPA8000 is connected directly to the wall socket via the power cord provided.*

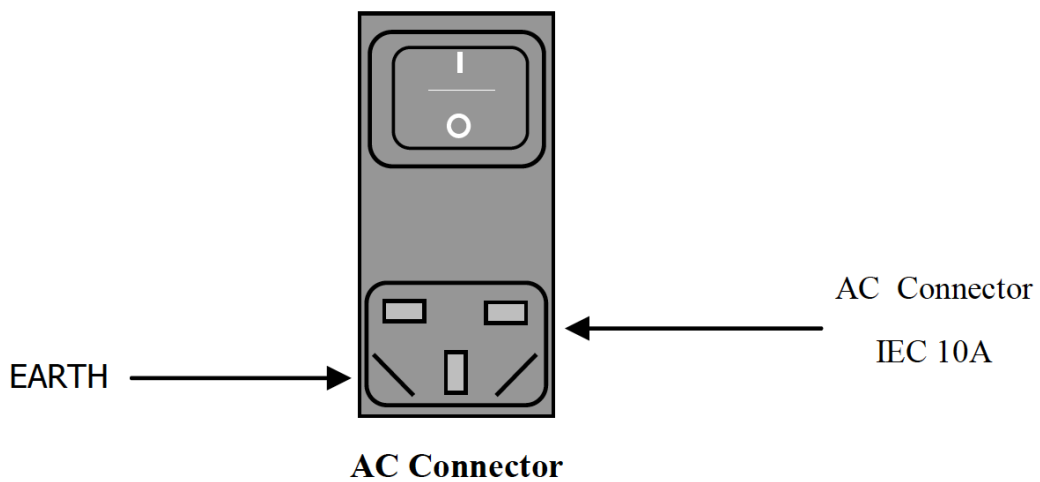

## Powering up

Press the rear panel power switch on. Press the front panel switch marked power until it latches. The display and internal illumination will light up. The display will show the selected input.

## Powering down

Press the front panel switch marked power and release. The Ultima Pre utilises soft start circuitry so the power can be switched on and off as often as required. There is no need to leave the Ultima Pre permanently switched on.

# Connecting your equipment

Chord amplifiers are supplied with and designed to be connected using balanced inputs. The interconnecting cables you use will depend on the available input and output sockets on your other equipment. We have installed unbalanced inputs on all Chord equipment, thus enabling you to mix Chord Electronics and other manufacturer's equipment.

Balanced inputs carry twice the strength of signal of unbalanced inputs and are able to be fed down long lengths of cable with less deterioration of signal. They are also less prone to interference than unbalanced inputs. Balanced inputs have three pins and use Neutric XLR style connectors. Pin 1 is earth, pin 2 is positive and pin 3 is negative.

Unbalanced inputs use RCA phono connectors, which are gold plated with teflon high performance dielectric insulators for optimum performance.

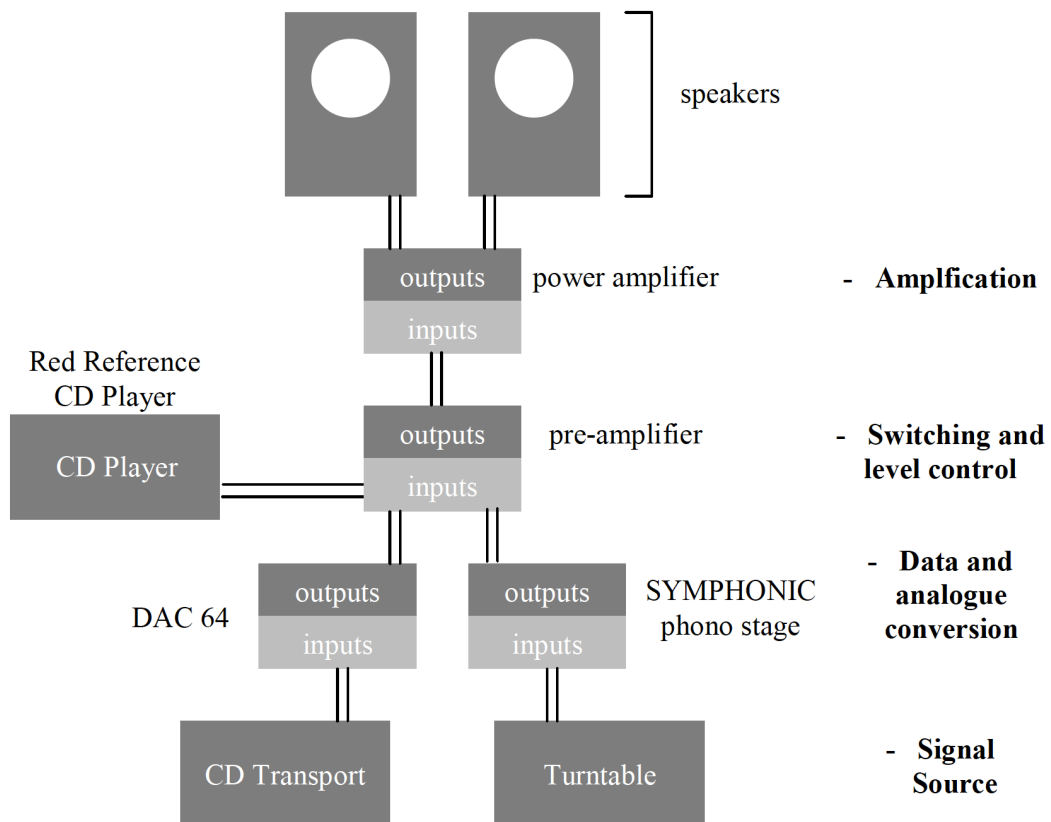

**Basic system diagram**

# Input Connections

You can connect up to 8 items of source equipment. Included in this are two tape loops for recording purposes. All input connections are on the rear panel and are marked with the corresponding Line number. Lines 1 to 4 are balanced inputs, Line 5, 6, 7 ( Tape 1 ) and 8 ( Tape 2 ) are RCA phono style inputs. Left channel connections are at the top, right channel connections are at the bottom.

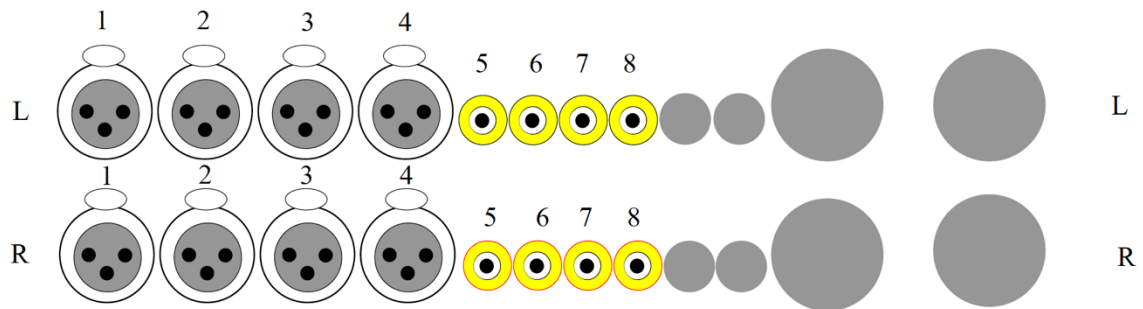

It does not matter which input you choose just select the same type of connection that your source has.

Note: Moving coil turntables without an internal amplifier will require an external phono stage amplifier such as the Chord Symphonic before connecting to the Ultima Pre.



# Output Connections

You need to connect the outputs on the back of the Ultima Pre to a power amplifier in order to drive your loudspeakers. There are three pairs of balanced XLR outputs and three pairs of RCA phono outputs, each of which will drive a 68 ohm load. Choose either depending on the appropriate input connection on your power amplifier. Left channel connections are on the left, right channel connections are on the right, each output is identical.

*Note: For optimum performance it is recommended that the balanced outputs are used where possible.*

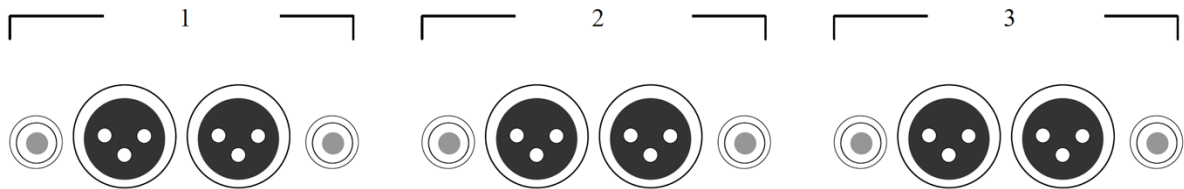

If you wish to bi-amp or tri amp then you can connect up to three sets of amplifiers to the output connections.

# Recording

You can record an input from another audio source or two sources at the same time. If you've been using a tape recorder as an input source, it will already be connected to the 7 or 8 input sockets. If you haven't, first connect the tape's output to the 7 or 8 input sockets.

Connecting to a Tape recorder to tape an audio source:

Use RCA connectors to the left and right pairs marked TAPE O/PS 1 or 2, or both.

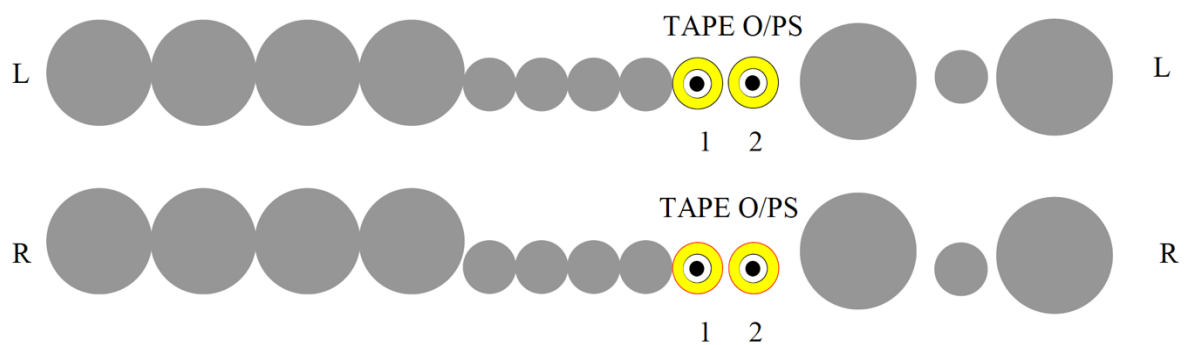

## Selecting the bus

Your amplifier has two input selection buses. The default bus is bus A and this is the one you would use to choose your inputs in everyday operation. The advantage of having two buses is that it allows for two tape recorders to tape (different inputs) simultaneously.

Bus A is permanently connected to the Tape 1 (1) output and Bus B is permanently connected to Tape 2 (2) output.

You can tape from any source to either of the tape recorder outputs and both outputs can be monitored.

For example: You can play a CD on Line 1 on Bus A and record this by connecting your tape recorder to the Tape 1 (1) output. At the same time you can play a radio on Line 2 and connect another tape recorder to the Tape 2 (2) output to record the radio. Simply switch between Bus A and Bus B to monitor either of the sources. If you are recording an input on one Bus you can still listen to another input whilst recording simply by selecting the other bus.

**Note:** In these examples we have used a tape recorder but you can use any recording device with a phono input. Minidisc, CD/DVD recorders and PC soundcards are all normally compatible.

If you wish to record from one tape recorder to another then you will need to swap the tape recorder outputs. Connect the first tape recorder to 7 IN and 2 OUT then the second to 8 IN and 1 OUT. Play the tape on BUS A Tape 1 then record on the other tape recorder.

# EQ Frequency Controls

On the front panel are the EQ frequency controls. There are four controls, two for each channel, one for high frequency and one for low frequency. Using these you can adjust the low and high frequency response for the left or the right channel. The settings affect all the inputs and outputs but not the AV bypass or tape output loop.



To activate the EQ frequency controls press the OP1+2 button on the remote control. The display will show EQ on. You can then adjust the frequency response to suit the room conditions. To switch off the EQ and bypass the circuit for a standard response press the OP1+2 button again until the display reads EQ OFF.

**Please note due to the headroom required for the frequency EQ adjust the gain will be lower. Please take care when switching the EQ OFF that you reduce the volume accordingly.**

# AV Bypass

AV Bypass mode allows the output of an AV surround sound processor to be connected and then routed directly to the output of the Ultima Pre. The volume control and signal processing are bypassed so that the signal from the AV processor reaches the power amplifier exactly as if it were connected directly. This has the advantage of allowing the Ultima Pre to remain in an AV system to give the best possible stereo two channel playback whilst still being able to switch to AV bypass mode to allow the processor to playback multichannel film content. An AV Bypass Monitor output is provided to check signal integrity or to connect to another AV processor.

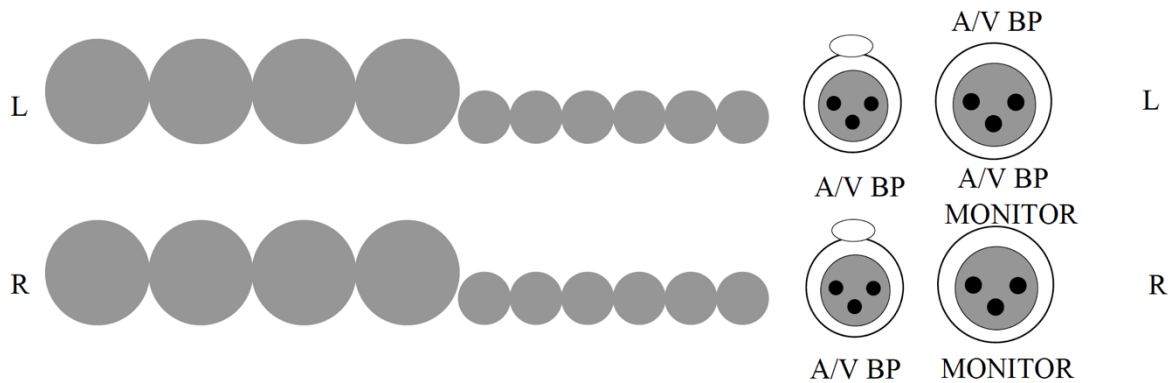

Connect the front left and right outputs from your AV processor to the inputs on the back of the Ultima pre marked A/V. Connect to the power amplifier as normal via either the balanced or RCA output on the Ultima Pre. Press the SET button or Bypass on the remote control to activate the bypass option.

Note: The volume control in the Ultima Pre will be bypassed so please check before switching on your AV processor that the volume is turned down. When switching back please check that the volume on the Ultima Pre has not inadvertently been turned up before playing any music.

# Headphones

The Ultima pre features two  $\frac{3}{4}$  inch headphone sockets on the front panel.

## To turn on headphone mode

1. Insert the headphone jack(s).
  2. Press the SET button several times until H-PHN is displayed.
- Headphone mode automatically mutes your loudspeakers. Headphone mode also prevents any volume control from automatically un-muting your loudspeakers.

## To turn off headphone mode

1. Press the SET button several times until your chosen output is displayed or
2. Press Mute on your remote control or
3. Press OUT1 on the remote control.

# Everyday use of your Ultima Pre

## Turning on your Ultima Pre

Press the power button on the front of the Ultima Pre. Press again to switch off.

## Select the input source

Press and hold button A on the front panel to select Bus A. Your Ultima Pre should be set to Bus A for normal operation and the display will read the last selected input with no dots underneath. The selected input will automatically be sent to the tape recording T1 phono outputs:



To assign the main output with a particular input signal, press button A and release several times to cycle through the 7 line inputs until the one you wish to use is displayed. The options are shown in the diagram below:

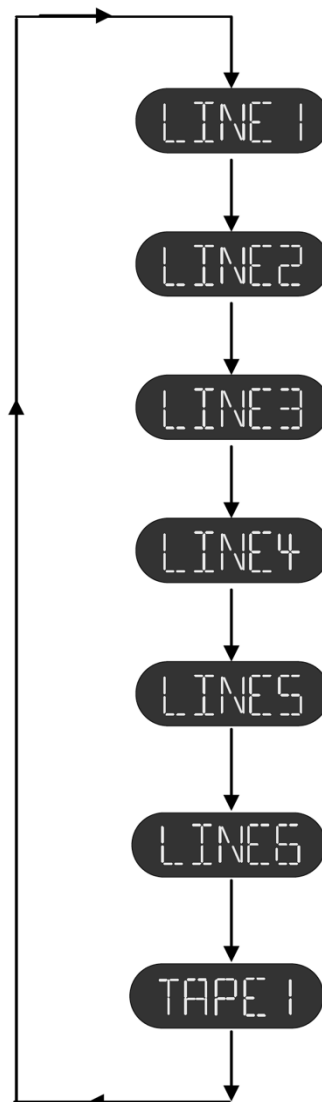

### Cycle of input selection options for Bus A

To select Bus B press and hold the B button on the front panel. The currently selected line input will be displayed with dots underneath to indicate Bus B. The selected input will automatically be sent to the tape recording T2 phono outputs:



Press and release the B button to cycle through the inputs:

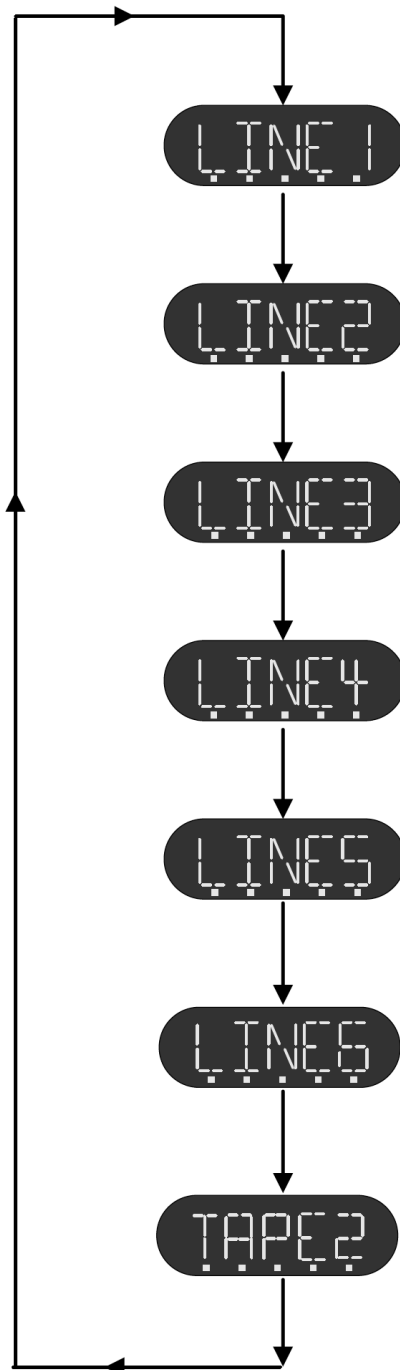

## Cycle of input selection options for Bus B

### Select the output

Press the SET button to select the output.

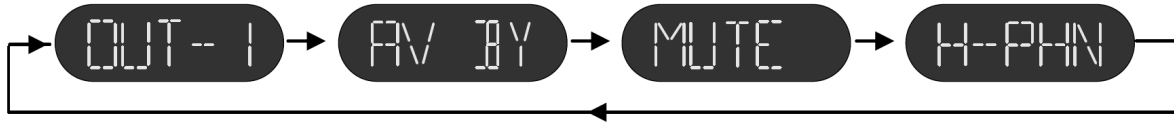

### Adjusting the volume

Use the volume knob to adjust the volume manually. A clockwise turn of the knob will increase the volume and an anti-clockwise turn of the knob will decrease the volume. The volume range runs from 0 to 98 and is displayed on the Ultima Pre display as you change the volume. If the outputs are muted, a volume change will un-mute the outputs to prevent large changes in volume from damaging your loudspeakers. The volume level is shown on the display as the word VOL and a two digit level as shown in the example diagram below.



Volume display

### Changing the balance

Use the balance knob to shift the balance between the left and right loudspeaker. A clockwise turn of the knob will shift the balance to the right speaker and an anti-clockwise turn of the knob will shift the balance to the left speaker.

### Switching the VU meter

Press the front panel button marked VU to switch the VU display on and off.

# Using the remote control

The Ultima Pre is supplied with the system remote control that is a universal controller for all Chord products, televisions and DVD players. Full instructions can be found in the System Remote Manual supplied but for the purposes of controlling the Ultima Pre the main functions are listed on the next few pages.



Press the HIFI key to begin controlling the CPA8000.



### **Selecting the input source**

Press the Line- or Line+ keys on the centre control to cycle through the inputs.

For convenience you can directly access the first 5 inputs using the buttons at the bottom of the remote control.

The main everyday Bus A inputs are on the left whilst the Bus B inputs are on the right.

Press the button marked BUS A to select Bus A so you can listen to the source connected to this bus. Press the button marked BUS B to select Bus B so you can listen to the source connected to Bus B. Bus B inputs are shown with dots underneath.

( As an example you can listen to your CD player on Line1 Bus A whilst recording the radio on Line2 Bus B. Press BUS B then Line2. Start recording. Then press BUS A then Line1 to listen to the CD player. )

### **Adjusting the volume**

Press the Vol+ button on the centre control to increase the volume, press the Vol- button on the centre control to decrease the volume.

### **Adjusting the balance**

Press the Bal+ button to move the balance towards the right. Press the Bal- button to move the balance to the left.

### **Changing the output**

Press OP1 to select the main output. Press BYPASS (OP2) to select AV Bypass output. OP1+2 selects the EQ frequency control.

### **Mute**

Press the mute key to mute the Ultima Pre.

### **To un-mute**

Press the mute key again, or select an output, or change the volume.

# Input Gain Control

You can adjust the input gain on any of the Line inputs so that you can align the volume levels of your different sources. There are six steps, which are x0.50, x1.00, x1.5, x2.00, x2.5 and x3.00. Most modern input devices such as CD players have an unbalanced output voltage of 2.5V and a balanced output 5V which does not require any increased gain amplification. In fact, to increase the gain on such an output level can lead to distortion of the signal. However, older audio equipment may have an output voltage of less than 2V, in which case you may like to adjust the input gain.

**Note:** When using the Chord QBD76 please set the line gain to 0.5.

## Increasing the input gain

1. Select the Line and Bus with the source that requires increased gain ( e.g. Line2 Bus A).
2. On the remote control press BUS A ( or BUS B if you are using this bus ). The display will show the currently selected gain for this input.
3. Press the Vol+ key on the remote control to increase the gain.
4. Repeat steps 2 and 3 to continue increasing the gain.



Example increasing gain on Bus A

## Decreasing the input gain

1. Select the Line and Bus with the source that requires the gain to be reduced ( e.g. Line2 Bus A).
2. On the remote control press BUS A ( or BUS B if you are using this bus ). The display will show the currently selected gain for this input.
3. Press the Vol- key on the remote control to decrease the gain.
4. Repeat steps 2 and 3 to continue decreasing the gain.

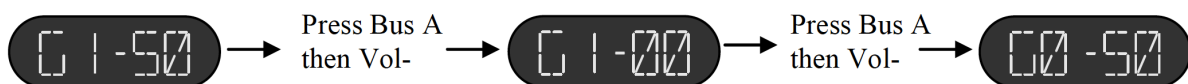

Example decreasing gain on Bus A

# Maintenance

## **Adjusting the settings**

Always remember to make any changes to settings with the volume set low or an instant burst of sound could damage your loudspeaker.

## **Cleaning**

To clean finger marks and other blemishes from your amplifier spray clear glass cleaner onto a soft lint free cloth and then use the cloth to gently clean your amplifier.

## **Changing the batteries in the remote control**

Simply push the button on the bottom of your remote control to release the battery cover. Replace with four new AAA batteries as shown inside the battery compartment.

## **Servicing**

There are no user serviceable parts in your Chord amplifier, and it should only be serviced by Chord Electronics Limited or their expressly approved Service Agents.

# Frequently asked questions

## **Why aren't any of the remote control buttons working?**

Press the HIFI button to set up the remote control for pre-amplifier functions.

## **I've connected all the wires up but I can't hear any sound?**

Ensure that you've selected the correct bus (typically Bus A), the correct input (e.g. Line 1) and the correct output (e.g. Output 1).

## **Why is there humming coming from the loudspeakers?**

Check that you've earthed the unit. The interconnects need to be properly screened and placed away from mains cables. Interference can be reduced by using balanced inputs and outputs instead of RCA phono types.

## **The sound coming from the loudspeakers is distorted**

Check that the speakers are connected properly. It may be that the volume is turned up too loud for your speakers or that you have set the gain for the input device too high.

# Trigger Outputs

The Ultima Pre features three trigger outputs that can be used to remotely trigger other Chord equipment. The external trigger should be connected via a standard 1/8th inch / 3.5mm (mono or stereo) jack plug to the socket fitted to the rear of the unit. The trigger outputs will go high when the Ultima Pre front panel power switch is pressed on.

The Ultima Pre should be switched off, the trigger lead inserted, then the unit switched back on.

The connections are as follows:

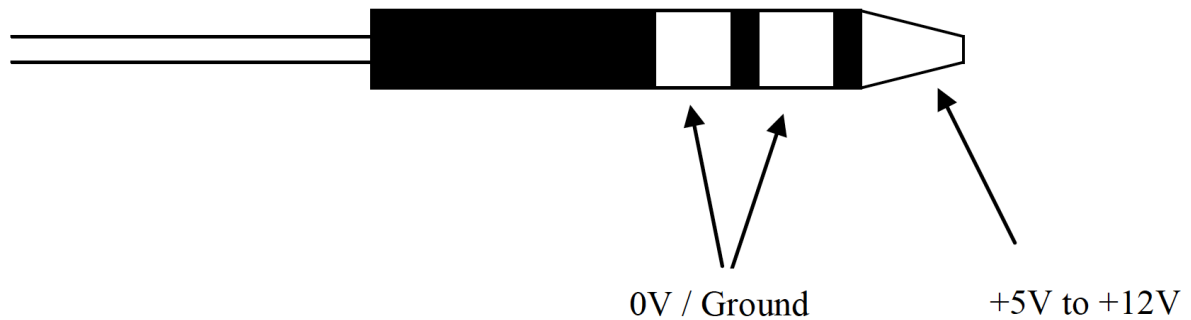

The tip of the plug is the +5V to +12V dc connection, the centre and rear connection are the 0V or ground connection.

# IR Control

The socket on the rear panel marked IR CONT will connect to the IR remote control receiver within the Ultima Pre. When using room control systems you can connect the remote signal discretely to this socket rather than using an external IR repeater stuck to the front panel display.